



Aerobic Lateral Trainer



Please read carefully before using.

H901

ASSEMBLY MANUAL

TABLE OF CONTENTS

1	IMPORTANT SAFETY INFORMATION	2
	Important Safety Precautions	2
	Weight Limit Capacities	2
	Warning	2
2	BEFORE YOU BEGIN	3
	Unpacking Information	3
	Pre-Assembly Check List	3
	Pre-Assembly Check List Drawing	3
3	ASSEMBLY	4-10
4	GETTING STARTED	11
	Computer Instructions	11-12
5	CUSTOMER INFORMATION	
	Customer Service	13

READ ALL INSTRUCTIONS BEFORE USING

1/ IMPORTANT SAFETY INFORMATION

THIS OWNER'S MANUAL CONTAINS ASSEMBLY, OPERATION, MAINTENANCE AND SAFETY INFORMATION. IN THE INTEREST OF SAFETY, PLEASE MAKE CERTAIN THAT YOU READ AND UNDERSTAND ALL THE INFORMATION BELOW.

IMPORTANT SAFETY PRECAUTIONS

1. Read the OWNER'S OPERATING MANUAL and all accompanying literature and follow it carefully before using your machine.
2. Inspect your exercise machine prior to exercising to ensure that all nuts and bolts are fully tightened before each use.
3. Most exercise equipment is not recommended for small children. Children should not use the machine unless they are under adult supervision.
4. Exercise equipment has moving parts. In the interest of safety, keep others, especially children, at a safe distance while exercising.
5. Warm up 5 to 10 minutes before each workout and cool down 5 to 10 minutes afterward. This allows your heart rate to gradually increase and decrease and will help prevent straining muscles.
6. Never hold your breath while exercising. Breathing should remain at a normal rate in conjunction with the level of exercise being performed.
7. Rest adequately between workouts. Muscles tone and develop during these rest periods. Beginners should work out twice a week and increase gradually to 4 or 5 times per week.
8. Remove all jewelry, including rings, chains and pins before commencing exercise.
9. Always wear suitable clothing and footwear during exercise. Do not wear loose fitting clothing that could become entangled with the moving parts of your exercise machine.
10. This machine is intended for household use only. It is not designed for commercial use.

IMPORTANT!!! THE MAXIMUM RECOMMENDED WEIGHT CAPACITY FOR YOUR Helix is 130Kg (286 lbs.) per user.

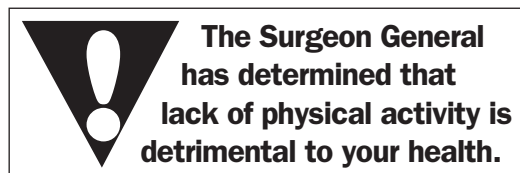

WARNING: Before commencing with any exercise program, please consult your family physician. If at any time during exercise you feel faint, dizzy or experience pain, stop and consult your family physician. In the event any of the above mentioned warnings are breached by the consumer, the manufacturer may use same as a defense to any claim for injuries, damage or loss. The above warnings are in no way intended to limit or modify the consumer's remedies for breach of warranties pursuant to applicable Federal and State Laws of Regulations. They are being supplied strictly to ensure the safety of the individuals using this product.

2/ BEFORE YOUR BEGIN

IMPORTANT: Read all instructions carefully. Assemble the Helix in accordance with the steps in the manual. All tools required for assembly are included with your Helix. Lay out all parts on the floor. Make sure that you have all the parts listed below before beginning assembly. In case of a discrepancy, please contact our Customer Service Department at the email address or customer service number listed on Page 11 of this Owner's Manual.

PRE-ASSEMBLY CHECK LIST

Item #	Description	Qty	Item #	Description	Qty
1	LEFT AND RIGHT FRAME LEGS	2	10.	PEDAL COVER BOLTS	4
2	END CAPS FOR FRAME LEGS	2	11.	PEDAL FRAME BOLTS	6
3	PEDAL FRAME AND COVERS	2	12.	COMPUTER BOLTS	4
4	MAIN FRAME	1	13.	ALLEN HEAD UPRIGHT BOLTS	4
5	RUBBER CIRCLE FOR UPRIGHT	1	14.	HEX HEAD UPRIGHT BOLTS	2
6	COMPUTER	1	15.	HANDLEBAR NUTS	4
7.	CENTER UPRIGHT TUBE	1	16.	ASSEMBLY TOOLS	5
8.	HANDLEBAR	1	17.	WATER BOTTLE HOLDER	1
9.	TOP COVER	1	18.	WATER BOTTLE HOLDER SCREWS 2	

Note:

Some parts may be factory pre-assembled.

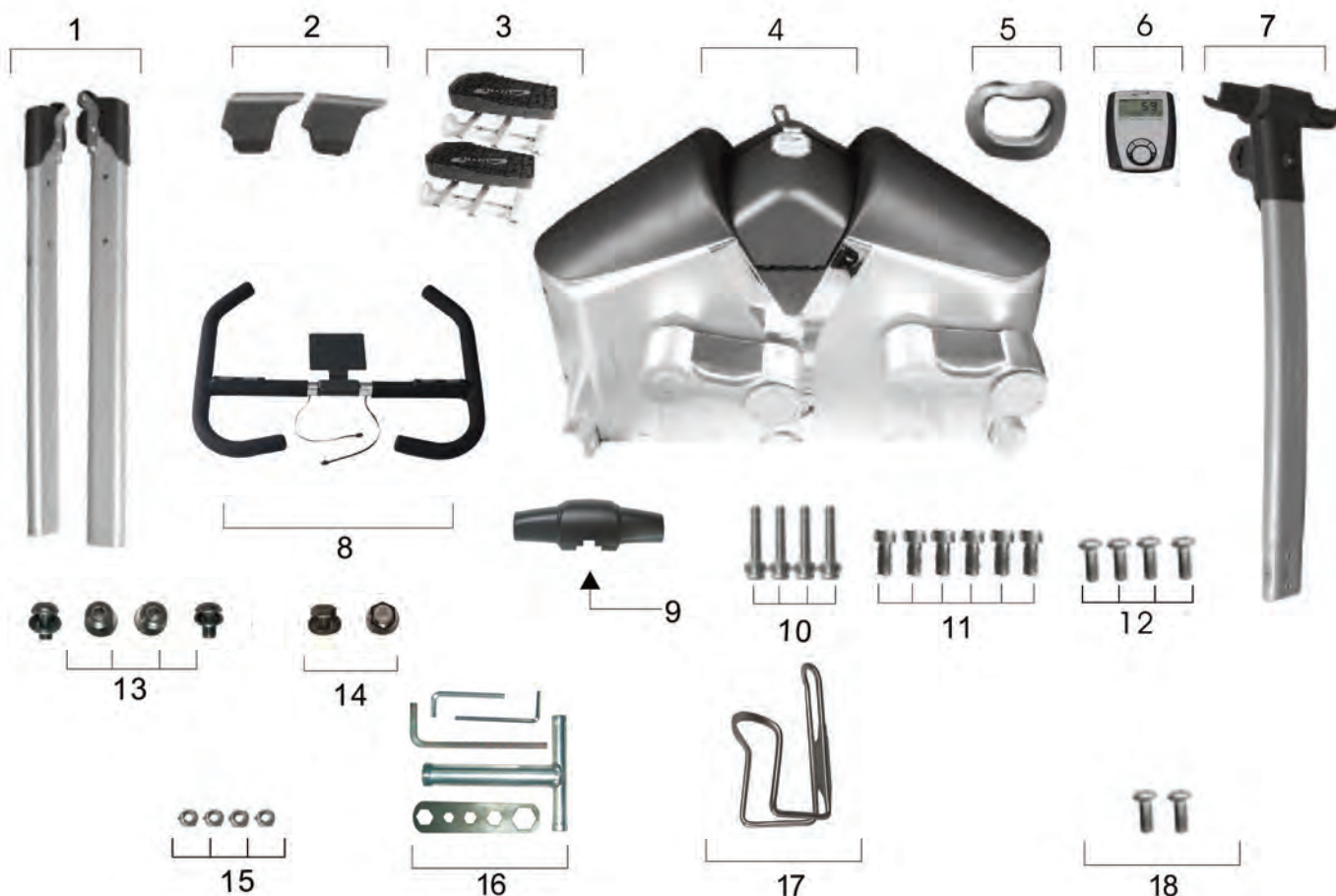

3/ ASSEMBLY



IMPORTANT:
Do not remove the Helix from the box bottom until further instructed later in this assembly manual.

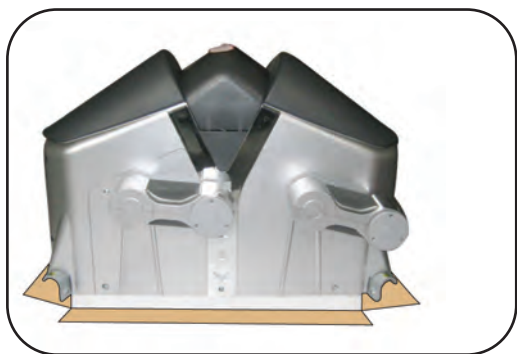

STEP 1:

Put the product on the floor and remove the top box cover to reveal the Helix as show above. Where the box corners are printed “OPEN”, cut or tear the box and separate these corners. Lay the sides flat to the floor

Remove all parts from the box leaving just the main body of the machine on the bottom of the box. remove all parts from their plastic bags and organise the floor beside the Helix

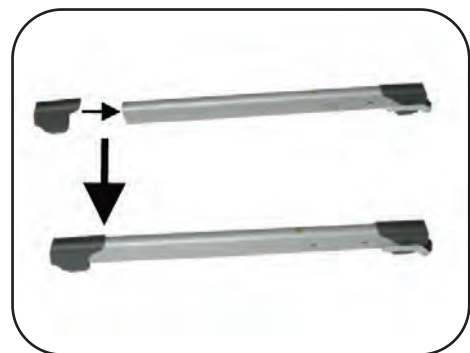
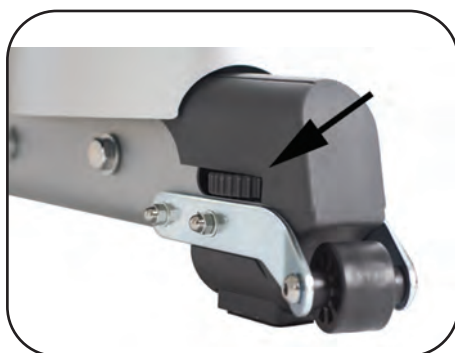

STEP 2:

Attach the End Caps (2) to the Left and Right Frame Legs. These caps are not specific to either side. They fit on left or right. If the Helix is not stable on the floor, turn the adjuster on the front end cap to raise or lower the height.

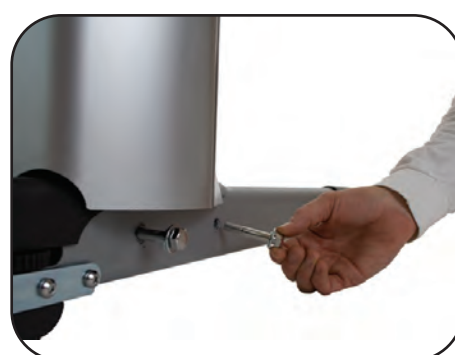
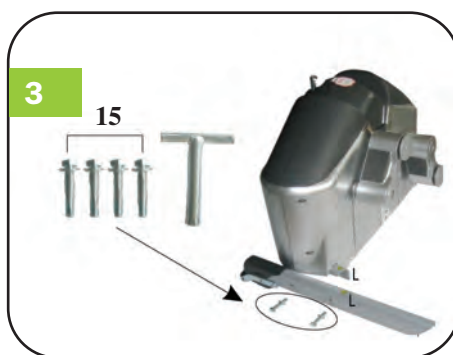

STEP 3:

Each Left and Right Frame Legs are marked “L” and “R” with a sticker. While facing the Helix, place the left left on the left side of the machine and the right leg on the right side of the machine.

Insert the Frame Leg assembly bolts into the lefts and secure using the “T” wrench as shown. Tighten these bolts firmly.

IT IS VERY IMPORTANT TO MAKE SURE THAT THE LEFT AND RIGHT FRAME LEGS ARE ON THE CORRECT SIDE OR THE HELIX WILL NOT ROLL PROPERLY

3/ ASSEMBLY

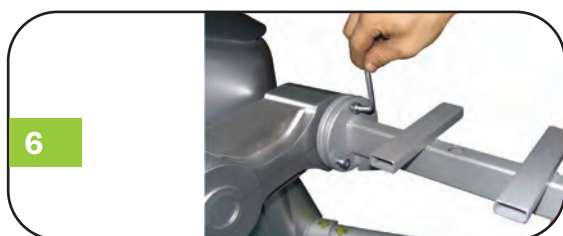
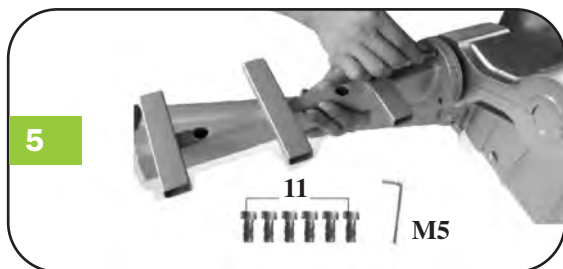

Separate the Pedal Covers from the Pedal frames as shown in FIG 4

STEP 4:

Holding the Pedal Frame as shown, align the bolt holes on the pedal frame with the bolts on the yoke of the Crank arm. There is an indentation on the Pedal Frame and a protrusion on the yoke. These should fit together to allow the Pedal Frame and yoke to become even and flush with each other.

While holding in place, first install the top bolt partially to allow the pedal frame to “hang” on that bolt. Use the Allen Wrench provide to tighten the bolts.

Now partially install the bottom left and bottom right bolts. Slowly tighten all the bolts until the two parts become perfectly aligned to each other with no space between the parts. Then Firmly tighten all three bolts.

STEP 5:

Place the Pedal Covers on the Pedal Frames and align to allow the frame to fit inside the cavities on the bottom of the Pedal Covers.

Install 2 Pedal Cover Bolts in each Pedal Frame and secure firmly. There is no need to over tighten these bolts. They should be firm but not excessively tightened.

IT IS VERY IMPORTANT THAT IN STEP 6,7 AND 8 TO FOLLOW EACH STEP VERY CLOSELY. IF A STEP IS MISSED OR SKIPPED, IT MAY REQUIRE DISASSEMBLY TO REMEDY THE ERROR AND STARTING AGAIN AT STEP 6.

ASSEMBLY OF THE CENTER UPRIGHT TUBE

STEP 6:

Holding the Center Upright Tube as shown, first slide on the Rubber Circle for Upright. The side of the Rubber Circle that has a minor indentation should be positions toward the back of the Center Upright Tube.

3/ ASSEMBLY

The back can be determined by the opposite side of the Tension Adjustment Knob.

After sliding on the Rubber Circle, then slide on the “Removeable Cover” The cover should be installed with the hole toward the back side of the Upright so that the majority of the cover sits on the front of the Center Upright Tube. (See **Figure #1**)

Once this is slid onto the Center Upright Tube, pull the elastic band around the tension knob to hold the cover up by the tension knob. This allows the cover to be out of the way for the bolt assembly of the Center Upright Tube.

See **Figure 2** (right)

STEP 7:

Remove all the wires from the center upright receiving tube as shown in **Figure #3**. The upright receiving tube is shown in the right half of **Figure #3** at the bottom of the circle.

Cut the plastic zip tab to release the wires and the cable.

IMPORTANT: Be sure not to allow the cable or the wires to slide back into the upright receiving tube.

Once you have removed the wires and cable, turn the tension dial on the front of the Center Upright Tube to the Right as far as it can go.

This is level 8 on the dial. This action will extend the cable at the bottom of the Center Upright Tube.

Take the cable that extends at the bottom of the Center Upright Tube and attach it to the cable that is in the Upright receiving tube. (See **Figure #5**)

Once attached, the cable should be as shown in **Figure #6**.

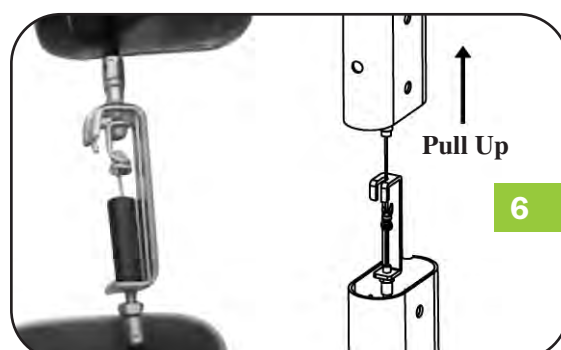
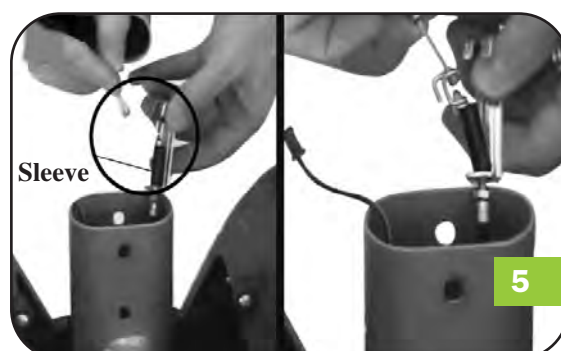
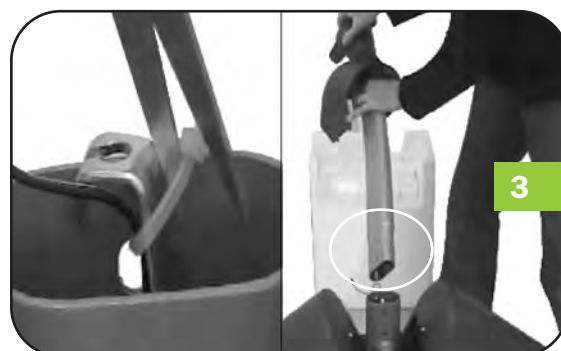

3/ ASSEMBLY

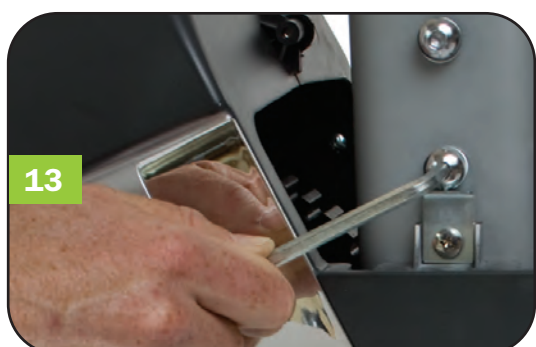
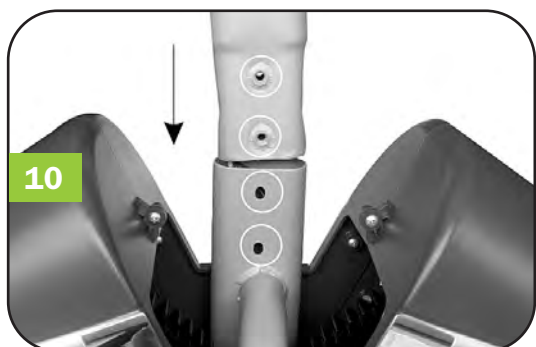
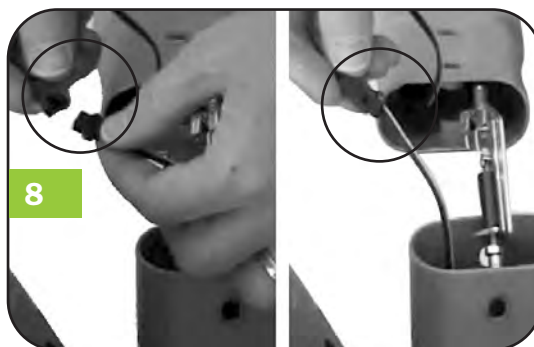

Next, Turn the Tension adjustment knob all the way to the left to level one. This should release the tension on the black “sleeve” that is surrounding the cable as shown in **Figure #7**. If the adjustment has not completely loosened the tension on the sleeve, Pull up on the Center Upright Tube as shown in **Figure #6** on previous page. This should release the tension from the black sleeve. Do not yet remove the black sleeve.

Attach the wires from the Center Upright tube to the wires protruding from the Upright Receiving Tube. Once attached, push the extra length back into the tube.

STEP 8:

Carefully remove the black sleeve and slide the Center Upright tube into the Upright Receiving Tube. First install 2 HEX head bolts (14 parts list) on each side of the upright as shown. Tighten with Hex Tool (**Figure #11**). Do not fully tighten at this time.

After installing 2 Hex Head bolts on either side of upright, install 4 Allen Head Bolts in front and back of upright as shown in **Figure #13**

After installing and fully tightening the 4 Allen Head Bolts, fully tighten the 2 hex head bolts on the sides of the upright with the Hex Bolt tool.



3/ ASSEMBLY

STEP 9:

Remove elastic cord from around the tension adjuster knob and then cut the cord to remove from the cover.

Slide the cover down to the bottom of the center upright tube and fit the tabs into the holds in the lower plastic housing to fit snugly in place as shown. Apply only gentle pressure to fit the tabs and the cover in place.

Slide the rubber circle down the center upright tube and push into place as shown.



FIXING THE HANDLE BARS



STEP 10:

- a. The Center Upright Tube has a plastic cover at the top. On the left side, you will notice a wire. (See Figure #1 above.) Make sure to place this over the back of the plastic lower cover so that when you place the handle bars on the bolts, the wire is behind the handle bars.
- b. Place handle bars on top of cover and align holes in bracket with the bolts protruding from the plastic section. While placing the handle bars on the bolts, hold the wire (as mentioned above) to the back to avoid being caught under the handle bars. (See Figure #2 above.)
- c. Install 4 Nuts onto bolts and secure with T-Wrench (include in tools). Tighten firmly.

3/ ASSEMBLY



STEP 11:

- a. There should now be 3 wires. two coming from the handle bars and one that you held from the upright when installing the handle bars. Hold all three wires together as shown in **Figure #1** above.
- b. Take Top Cover (**part #9**) and position with the notch in the rear to allow wires to come out. See arrow in **Figure #2**.
- c. Place plastic cover top onto the matching lower cover while making sure the wires are held through the notch. (**See Figure #3**)
- d. Gently snap the top cover onto the lower cover until all edges are flush. Gentle but firm pressure is required to snap the two covers together. (**See Figure #4**) for method to press parts together. **See Figure #5** for final fit with wires in hand.



WATER BOTTLE HOLDER INSTALLATION

STEP 12:

Find the two bolt holes with bolts pre-installed in the Center Upright Post and remove those bolts (**Figure #1**)

Once bolts holes are empty (**Figure #2**) hold the water bottle holder up to the post as shown and install a bolt in the lower hole in the water bottle holder bracket (**Figure #3**) and through to the lower bolt hole on the upright.

Do not tighten at this time.

Tilt the water bottle holder upright to align the top hole in the bracket with the top hole on the center upright post. Install a 2nd bolt into that hole and then tighten with the allen key as shown in **Figure #4**.

COMPUTER INSTALLATION**STEP 13:**

Prepare Computer for installation. See Picture #1. Remove 4 bolts and extend 3 wires from the back of the computer. Do not install batteries in holder at this time. Note square ridge that will match up with metal computer bracket on handlebars.

Connect the three wires from the handle bars to the three wires on the computer. These wires should snap together easily. Do not force. Two wires are the same and it won't matter which is going to which wire. The 3rd wire is different and can only connect to each other. (See **Figure #4**)

Carefully tuck the extra wire into the hole in the back of the computer and/or into the plastic cover to allow the computer to be placed on the metal bracket. If the wires are too long, the extension wires can be disconnected to shorten the length. This will not effect the function. (See **Figure #4**) highlight section.



Use 4 computer bolts to secure computer to brackets. tighten firmly but Do not over tighten.

Install 2 AA Batteries (included in Computer box) into the computer and replace cover.

4/ GETTING STARTED - COMPUTER

TOTAL RESET KEY

Press to total reset and come back initial setting mode. (set CLOCK / CALENDAR / TIME)

RECOVERY KEY

Measure user's recovery level.

DOWN-Decrease function value.

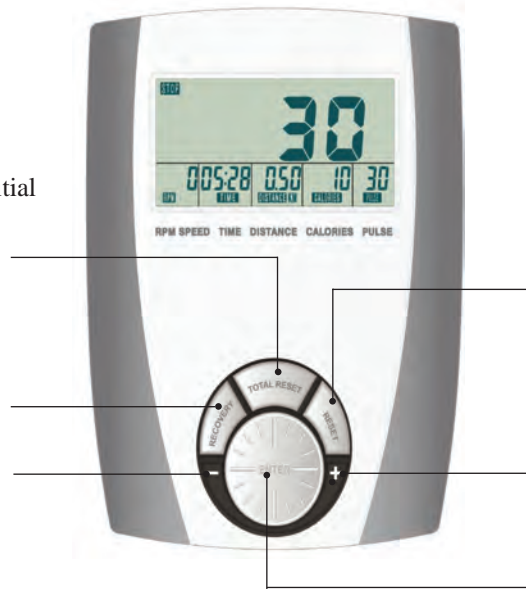

RESET KEY

Press key to reset function value to 0 for reset.

UP-Increase function value.

ENTER KEY & Knob

Press key to select function and confirm setting value.

A. WHEN DISPLAY IS ACTIVATED THE FOLLOWING WILL DISPLAY

Temperature Range	(32~99) (0~60)
Calendar Format	1900/1/1~2006/1/1~2099/12/31
Clock Format	24 HOURS / 0:00~23:59

B. FUNCTIONS

SCAN: When Scan is indicated on the screen, the Main display will change every 6 seconds. It will change to display as follows.

SCAN⇒RPM /SPEED⇒TIME⇒DISTANCE⇒CALORIES⇒PULSE⇒SCAN.

FUNCTION VALUE	DISPLAY VALUE	AVAILABLE SETTING	INCREMENTS
Speed (Kilometers or Miles)	0.0 to 99.9	None	None
RPM	Up to 999	None	None
Time	Up to 99:59 Minutes	Up to 99:00 Minutes	1 minute
Distance	0 to 99 KPH/MPH	0.00 to 99.00 KPH/MPH	0.50
Calories	Up to 9999	10 to 9990	10 calories
Pulse - BPM (beats per minute)	30 to 240 bpm	30 to 240 bpm	1 bpm

C. INITIAL START UP

After installing the batteries, the computer will beep an extended sound and the LCD will fully light 2 seconds as a test. The computer will then be ready for adjusting settings.

D. SETTING THE TIME & DATE:

Once the computer has initialized, it will automatically be ready to set the current time and date.

Please note: If no action is taken for 30 seconds, it will store the default time and date and be ready to function.

Setting the time and date are not required for proper computer operation.

After the computer initializes, the year will be flashing first. Change the year by rotating the dial clockwise or counterclockwise until the year is correct. When the correct year is showing, press "Enter" in the center of the dial. Next, the month will be flashing. Again, change the month by rotating the dial clockwise or counterclockwise until the month is correct. When the correct month is showing, press "Enter" in the center of the dial. Follow this same procedure to set the day, hour and minutes.

Please note: the clock function in 24 hour time. So, 8:00am is 8:00 and 8:00pm is 20:00.

4/ GETTING STARTED - COMPUTER

E. PROGRAMMING THE COMPUTER:

The computer will count up from zero as you exercise. The computer can also be programmed to count down from a desired time, distance or calories as you exercise. To count up from Zero, just begin exercising and the computer will start automatically to count up from zero. If this is not your first time using the Helix, you must first reset the values of each category to zero. See below.

Resetting to zero or setting a preset number for a category.

To begin, look in the top corner of the computer display. It should show STOP and possibly could show SCAN as well. It will only show stop when the Helix® is not in use. The computer will enter “STOP” mode after 4 seconds of inactivity.

Press “Enter” in the center of the dial. Then turn the dial either clockwise or counterclockwise to activate the setting function. You will notice one of the Time, Distance, Calories or Pulse will change settings. Note the item that changed. If you want to reset that item to zero, press the RESET key. If you want to set a goal value for the item, turn the dial either clockwise or counterclockwise until you reach the desired setting.

To reset or set another item, press “ENTER” in the center of the dial. The next item will begin to flash.

Once flashing, press RESET once to set to zero or turn the dial clockwise or counter clockwise to adjust the value. Repeat this process for each value.

When setting a value to the Pulse, when that value is exceeded, the pulse will flash. When you have finished, just begin to exercise and the computer will automatically start.

F. CALORIES:

The computer provides a rough guide of the calories expended during exercise. This is only an estimate and should be used more as a guide to compare one workout with another.

G. PULSE: Heart rate in beats per minute

To check your heart rate, place both hands on the handgrip sensors and hold firmly. After a period of up to 30 seconds, the computer will display your heart rate in beats per minutes (BPM). This test can be done while in motion or at a stop. Users may preset a target heart rate before starting by following the instructions in section E. above

H. RECOVERY TEST:

The computer tests your heart rate recovery by comparing your heart rate when you stop exercising until one minute after you stop. The change in heart rate helps to determine your level of fitness. To test your Recovery level, when you have finished your workout, place your hands on the hand pulse sensors until a heart rate is shown. Then press the RECOVERY button and return your hands to the sensors. The time will count down for 1 minute and then display your fitness level from F1 to F6. NOTE: during the RECOVERY test, no other functions will display.

SCORE	CONDITION	HEART RATE (FROM TEST HR LESS END HR)
F1	Excellent	Above 50
F2	Very Good	40 to 49
F3	Good	30 to 39
F4	Average	20 to 29
F5	Below Average	10 to 19
F6	Poor	Under 10

I. SLEEP Mode:

After you have stopped using the Helix, the computer will return to SLEEP mode after 4 minutes. In Sleep Mode, the computer will display the temperature, calendar and clock.

J. NOTES:

The computer requires 2 AA batteries. 2 Batteries are included with your computer for your convenience. After use, if there is any moisture on the computer, please just wipe it down to avoid moisture getting into the computer.



For customer service, we first recommend you contact the dealer where you purchased the Helix.
They will be able to resolve any issues the fastest.

If you cannot reach the dealer, please feel free to contact Helixco at
888-Helixco or by email to customer@helixco.com

Distributed under license from Kryptonite Corp by Helixco, a division of M & S Distribution, Inc, 136 Arlington Street, Boston, Ma 02116.

This product is patented in the US and other International Patents and patents pending.

US Patent Number 7,108,638

Helix® is a registered trademark of M & S Distribution, Inc. All rights reserved.